

Polygonal taper tool holders ISO 26623

2024

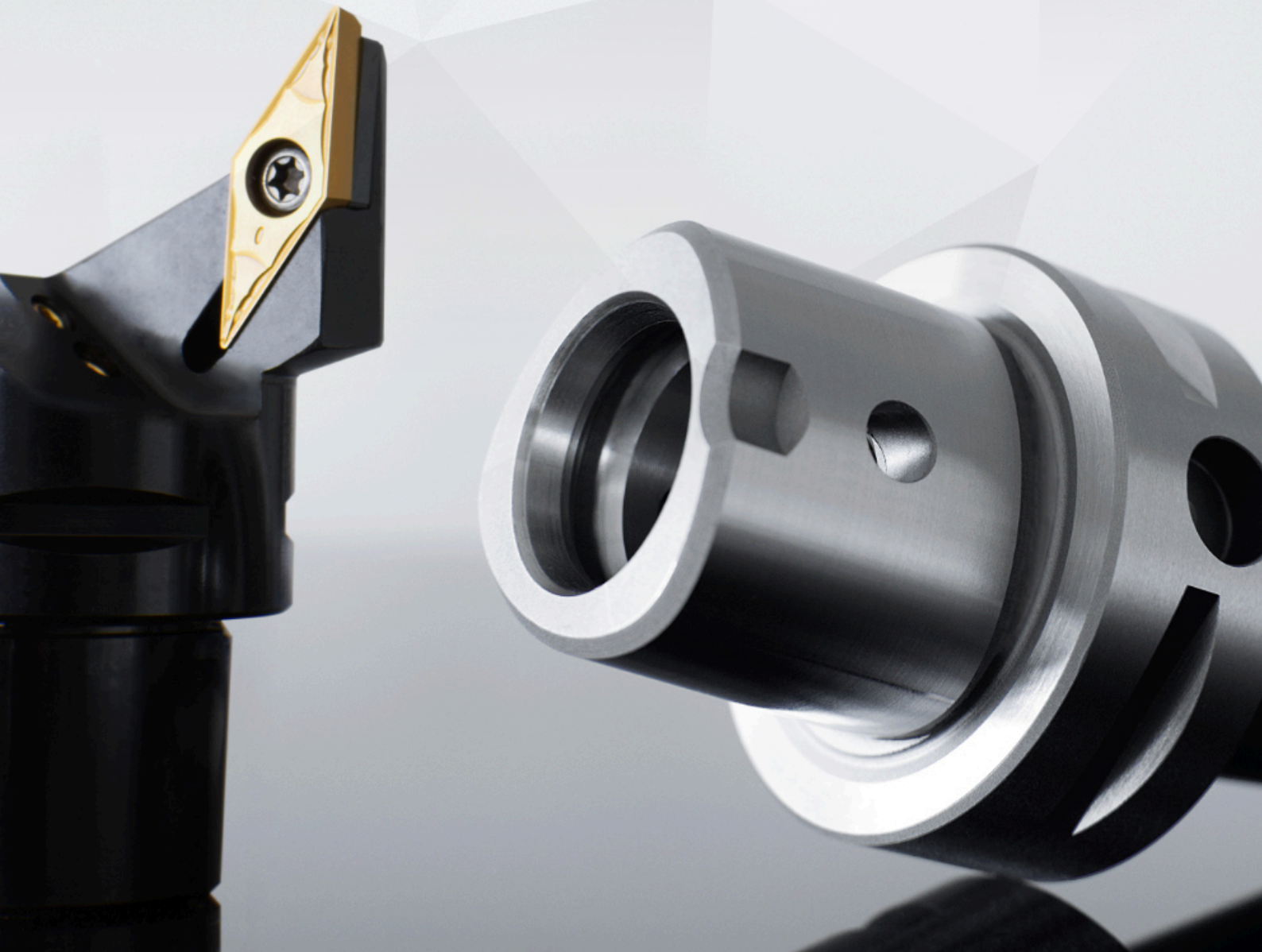

Polygonal taper tool holders - ISO 26623

Turning tool holders - multifunctional	10
Turning tool holders - external	12
Turning tool holders - internal	27
Turning tool holders - external thread	28
Turning tool holders - internal thread	29
Rectangular shank adaptors	30
Blank bars	32
Boring bar and indexable drills holders	33
PSC Reduction holders	34
Quick-change PSC reduction holder	34
PSC Extension holders	35
Quick-change PSC Extension holders	35
ER Collet chucks	36
ER Collet chucks - short adaptor	37
End mill holders	38
End mill holders - short adaptor	39
"3 in 1" THERMO Shrink-fit chucks	40
"3 in 1" THERMO Shrink-fit chucks - short adaptors	43
Shell mill holders	44
Shell mill holders - short adaptors	45



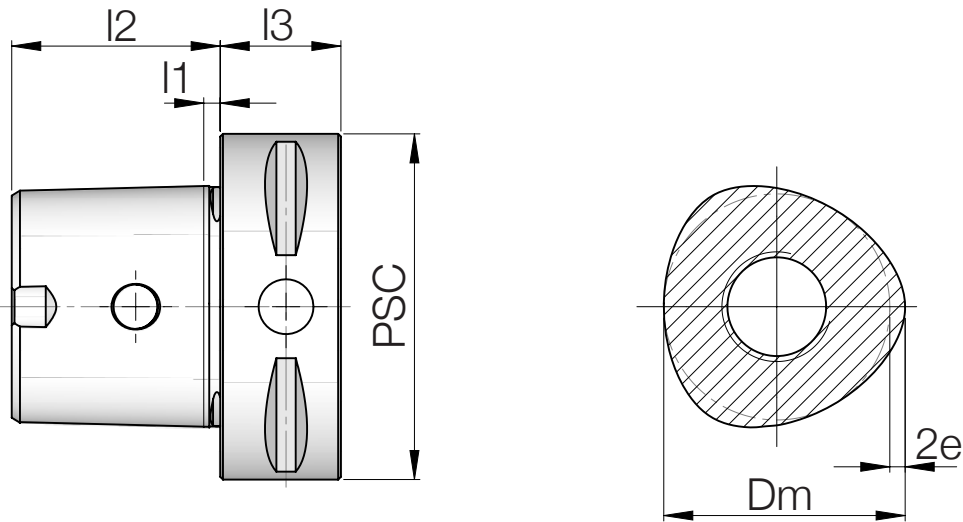

ISO 26623-1

PSC	Size	D_m	e	l_1	l_2	l_3 min.
40	C4	28	0.90	2.50	24	20
50	C5	35	1.12	3.00	30	20
63	C6	44	1.40	3.00	38	22
80	C8	55	2.00	3.00	48	30

Material: Case hardened steel with min. 900 N/mm² of core tensile strength.

Execution: Case hardened 58±2 Hrc. Depth of case 0.6 to 0.8 mm. Black oxidised.

Accuracy: Taper angle AT3 quality class. Roughness Ra < 0.5

All dimensions in this catalogue are in millimeters unless otherwise specified.

Full potential machining



Polygonal taper tool holders help you bring your machining to a new level.

As precisely defined per ISO 26623, PSC interface features unique tapered polygon which serves as a main element in torque transmitting, centering, and clamping. With double contact on both face and taper, as well as great cross-sectional strength, this interface is unrivaled in terms of high clamping force and bending stiffness.

Combination of these excellent properties give PSC interface clear advantage over HSK and 7/24 tapers with about 2x better bending and torsional characteristics. This translates into greater process stability, higher productivity, and lower costs.

Key attributes of Polygonal tool holders:

- Extremely stable and rigid connection between tool and the machine
- High torque and bending forces transmission due to simultaneous tapered polygon and face contact with machine spindle
- Self centering ability due to unique design
- Internal coolant supply, directly to the tool tip
- Best solution for all processes - both in turning and milling
- Modular design for flexible tooling
- Standardized interface as per ISO 26623
- 4 sizes, flange diameters 40-50-63-80 mm (sizes C4-C5-C6-C8)



Turning made better

PSC turning tool holders are go-to solution for maximizing process efficiency.

Used in both standard turn centers and hybrid mill-turn machines, PSC turning tool holders enable fast tool change solution for reduced down-time and increased productivity without compromise on stability and rigidity. Additionally, direct high pressure coolant nozzles increase tool life with higher feeds and speeds

More time making chips and less time in unwanted stops makes investment in Polygonal taper tool holders a great choice with a fast return.

Key benefits of PSC turning tools:

- Reduced setup and tool change time - maximum utilization of the machine
- Increased stability and versatility - in vertical lathes, multi-tasking machining centers and machining centers with turning possibilities
- Ultimate repeatability - allowing offline tool presetting
- Reduced tool inventory and storage space in workshop - due to universal interface for both turning and milling
- Self centering system provides high precision and repeatability
- Carbide shims to prevent insert seats from damage
- Quick change, monobloc system without additional interfaces

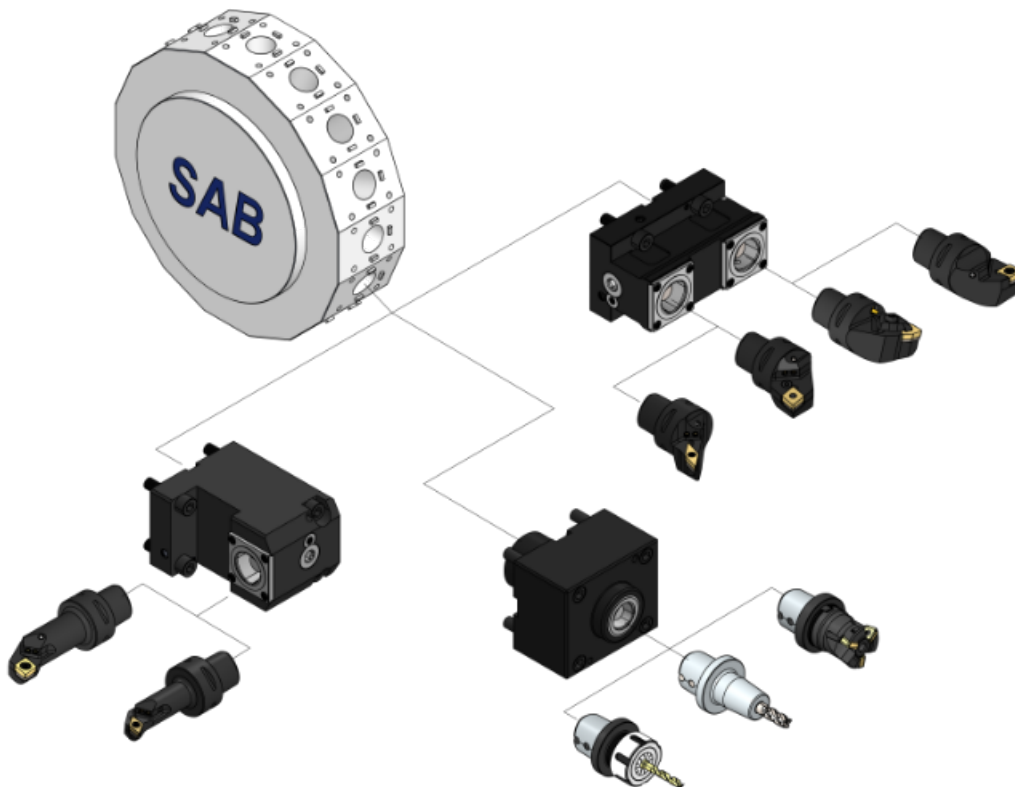

Short adaptor drives more benefits

Driven and static tools on your machine are best paired with short polygonal taper tool holders.

Short PSC adaptors have exactly the same ISO 26223-1 taper as normal PSC adaptors key with one difference - absence of gripper groove for automatic tool change. As a result, tool overhang is reduced which helps you achieve stable process, higher quality parts, and more efficient machining.

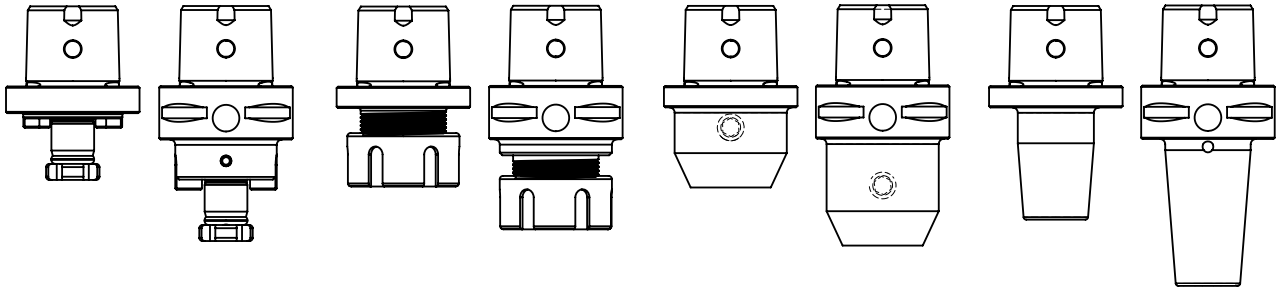

Key benefits of Short adaptors:

- Better cutting tool length availability
- Greater cutting stability due to shorter tool overhang
- Extended tool life and accuracy due to reduced tool runout
- Increased surface finish quality
- Decreased load on driven toolholder bearings
- Reduced setup and tool change time

High precision as standard

In order to ensure highest levels of quality, precision, and compatibility, SAB manufactures ISO 26623-1 tool holders using the same special inspection and manufacturing equipment and procedures as other major suppliers in the industry.

- Laboratory quality certified inspection equipment
- Inspection protocols equal to those of major industry competitors
- State-of-the-art manufacturing equipment
- ISO 9001 certified company
- AUKOM certified quality inspectors
- ISO 26623-1 compliant

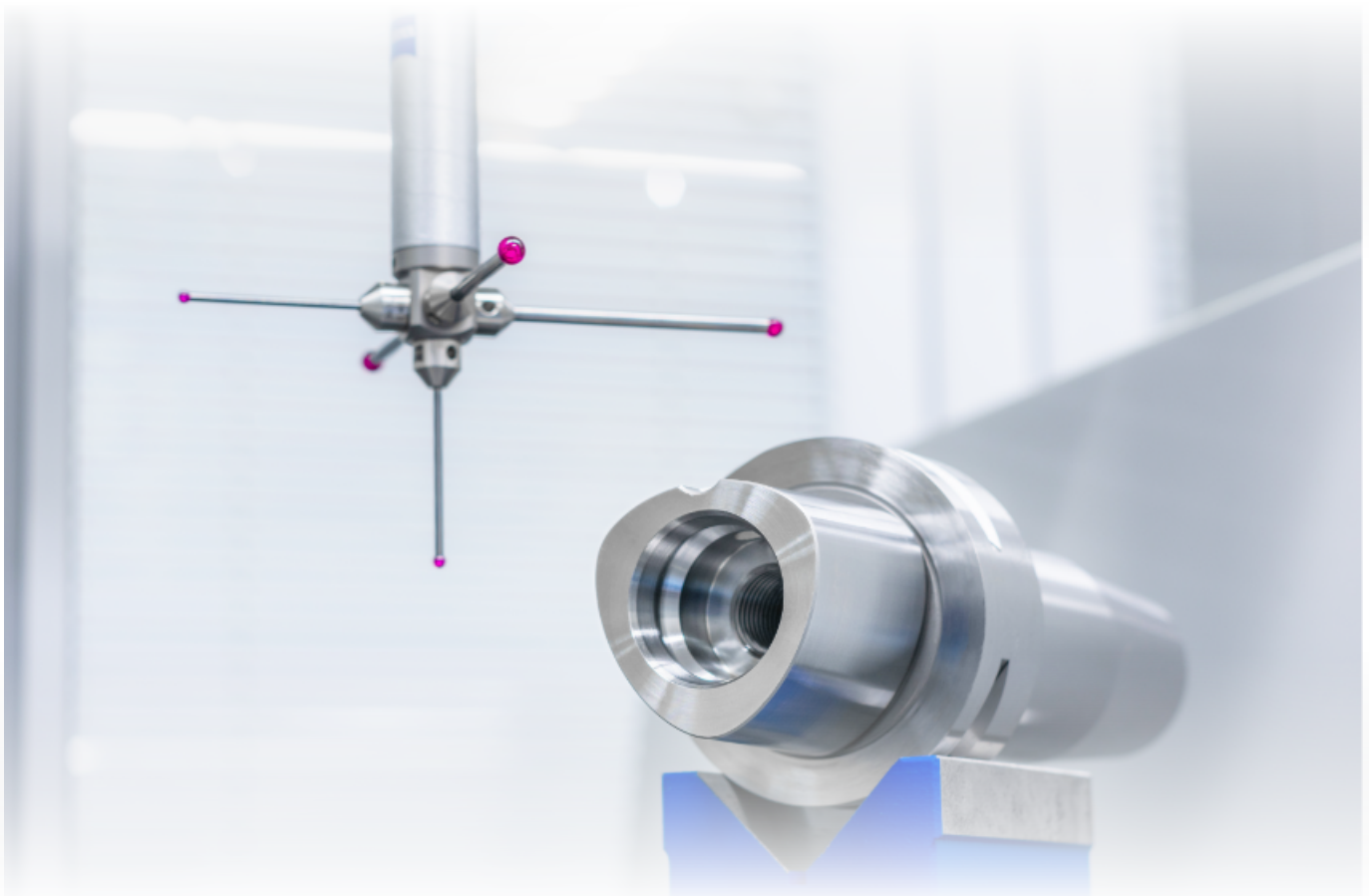
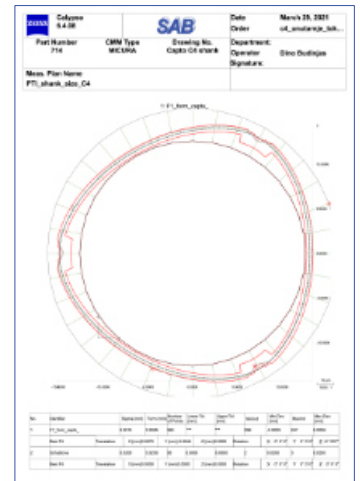

Turning tool holders - multifunctional

Internal and external
Lever-lock clamp
Direct coolant supply

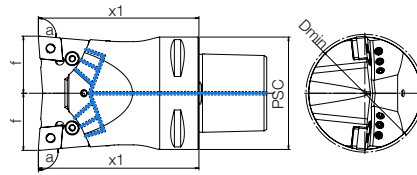

Size	Code	Orientation	Insert	PSC	a	x1	f	Dmin
C4	C4.TB.CN12CN12.060DC	Multi	CNM..1204..	40	95°	60	21	43
C5	C5.TB.CN12CN12.075DC	Multi	CNM..1204..	50	95°	75	26	53
C6	C6.TB.CN12CN12.090DC	Multi	CNM..1204..	63	95°	90	32	66

Spare parts	Lever	Lever screw	Shim	Shim pin	Key	Nozzle
Code:	POL.01	VPOL.0819	PPPC.12	OPP.01	KLJ.I30	ML.M4

Turning tool holders - multifunctional

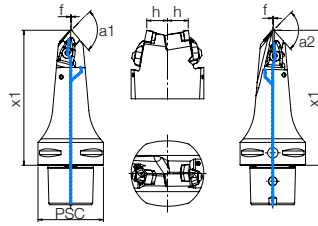

Wedge clamp
Direct coolant supply

Size	Code	Orientation	Insert	PSC	a1	a2	x1	f	h
C5	C5.T.DCM12DDM15.115DC	Left	CNM..1204/DNM..1506	50	95°	93°	115	0.5	20
C6	C6.T.DCM12DDM15.105DC	Left	CNM..1204/DNM..1506	63	95°	93°	105	0.5	20
C6	C6.T.DCM12DDM15.130DC	Left	CNM..1204/DNM..1506	63	95°	93°	130	0.5	20

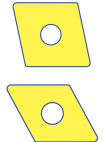

Spare parts	Clamp	Clamp screw	Shim	Shim	Shim screw	Key	O-ring set	Nozzle
Code:	SPKR/L	VPA.0620.DC	PPPC.12	PPPD.15	VPP.0512.KG	KLJ.I30	OR.VPA.DC	ML.M4

Turning tool holders - external

Wedge clamp
Direct coolant supply

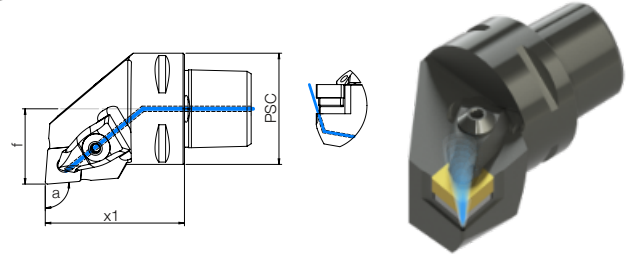

Size	Code	Orientation	Insert	PSC	a	x1	f
C4	C4.DCLNR/L.27050.12DC	Right/Left	CNM..1204..	40	95°	50	27
C5	C5.DCLNR/L.35060.12DC	Right/Left	CNM..1204..	50	95°	60	35
C6	C6.DCLNR/L.45065.12DC	Right/Left	CNM..1204..	63	95°	65	45
C8	C8.DCLNR/L.55080.12DC	Right/Left	CNM..1204..	80	95°	80	55

Spare parts	Clamp	Clamp screw	Shim	Shim screw	Key	O-ring set
Code:	SPKR/L	VPA.0620.DC	PPPC.12	VPP.0512.KG	KLJ.I30	OR.VPA.DC

Turning tool holders - external

Wedge clamp
Direct coolant supply

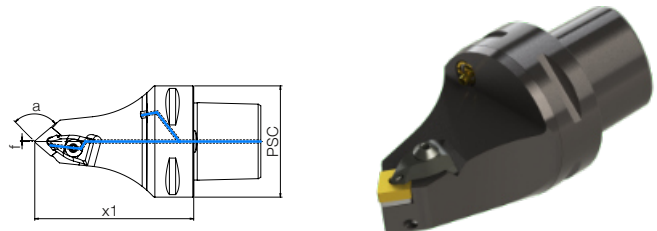

Size	Code	Orientation	Insert	PSC	a	x1	f
C5	C5.DCMNN.00105.12DC	Neutral	CNM..1204..	50	95°	105	0
C6	C6.DCMNN.00090.12DC	Neutral	CNM..1204..	63	95°	90	0
C6	C6.DCMNN.00115.12DC	Neutral	CNM..1204..	63	95°	115	0

Spare parts	Clamp	Clamp screw	Shim	Shim screw	Key	O-ring set	Nozzle
Code:	SPKR/L	VPA.0620.DC	PPPC.12	VPP.0512.KG	KLJ.I30	OR.VPA.DC	ML.M10

Turning tool holders - external

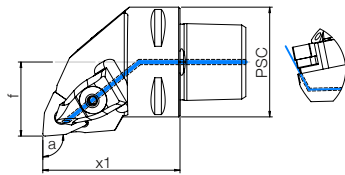

Wedge clamp
Direct coolant supply

Size	Code	Orientation	Insert	PSC	a	x1	f
C4	C4.DWLNR/L.27050.08DC	Right/Left	WNM..0804..	40	95°	50	27
C5	C5.DWLNR/L.35060.08DC	Right/Left	WNM..0804..	50	95°	60	35
C6	C6.DWLNR/L.45065.08DC	Right/Left	WNM..0804..	63	95°	65	45
C8	C8.DWLNR/L.55080.08DC	Right/Left	WNM..0804..	80	95°	80	55



Spare parts	Clamp	Clamp screw	Shim	Shim screw	Key	O-ring set
Code:	SPKR/L	VPA.0620.DC	PPPW.08	VPP.0512.KG	KLJ.I30	OR.VPA.DC

Turning tool holders - external

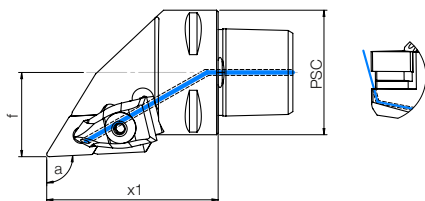

Wedge clamp
Direct coolant supply

Size	Code	Orientation	Insert	PSC	a	x1	f
C4	C4.DDJNR/L.27055.15DC	Right/Left	DNM..1506..	40	93°	55	27
C5	C5.DDJNR/L.35060.15DC	Right/Left	DNM..1506..	50	93°	60	35
C6	C6.DDJNR/L.45065.15DC	Right/Left	DNM..1506..	63	93°	65	45
C8	C8.DDJNR/L.55080.15DC	Right/Left	DNM..1506..	80	93°	80	55



Spare parts	Clamp	Clamp screw	Shim	Shim screw	Key	O-ring set
Code:	SPKR/L	VPA.0620.DC	PPPD.15	VPP.0512.KG	KLJ.I30	OR.VPA.DC

Turning tool holders - external

Wedge clamp
Direct coolant supply

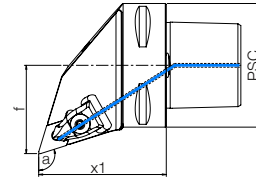

Size	Code	Orientation	Insert	PSC	a	x1	f
C4	C4.DDHNR/L.27055.15DC	Right/Left	DNM..1506..	40	107.5°	55	27
C5	C5.DDHNR/L.35060.15DC	Right/Left	DNM..1506..	50	107.5°	60	35
C6	C6.DDHNR/L.45065.15DC	Right/Left	DNM..1506..	63	107.5°	65	45
C8	C8.DDHNR/L.55080.15DC	Right/Left	DNM..1506..	80	107.5°	80	55

Spare parts	Clamp	Clamp screw	Shim	Shim screw	Key	O-ring set
Code:	SPKR/L	VPA.0620.DC	PPPD.15	VPP.0512.KG	KLJ.I30	OR.VPA.DC

Turning tool holders - external

Wedge clamp
Direct coolant supply

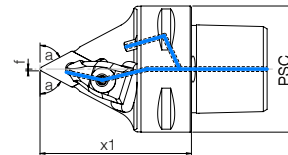

Size	Code	Orientation	Insert	PSC	a	x1	f
C4	C4.DDNNN.00055.15	Neutral	DNM..1506..	40	62.5°	55	0.5
C5	C5.DDNNN.00060.15	Neutral	DNM..1506..	50	62.5°	60	0.5
C6	C6.DDNNN.00065.15	Neutral	DNM..1506..	63	62.5°	65	0.5
C8	C8.DDNNN.00080.15	Neutral	DNM..1506..	80	62.5°	80	0.5

Spare parts	Clamp	Clamp screw	Shim	Shim screw	Key	Nozzle
Code:	SPKR/L	VPA.0520	PPPD.15	VPP.0512.KG	KLJ.I30	ML.M08 (C4) ML.M10 (C5-C8)

Turning tool holders - external

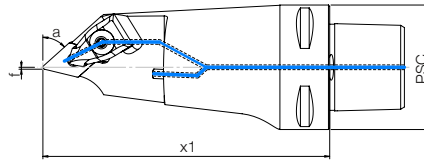

Wedge clamp
Direct coolant supply

Size	Code	Orientation	Insert	PSC	a	x1	f
C5	C5.DDMNL.00115.15DC	Left	DNM..1506..	50	48°	115	1
C6	C6.DDMNL.00130.15DC	Left	DNM..1506..	63	48°	130	1
C6	C6.DDMNL.33120.15DC	Left	DNM..1506..	63	48°	120	33
C8	C8.DDMNL.00160.15DC	Left	DNM..1506..	80	48°	160	1



Spare parts	Clamp	Clamp screw	Shim	Shim screw	Key	Nozzle	Spring
Code:	SPK (C5) SPKR/L (C6,C8)	VPA.0520 (C5) VPA.0620.DC (C6,C8)	PPPD.15	VPP.0512.KG	KLJ.I30	ML.M10	OPP.02 (C5)

Turning tool holders - external

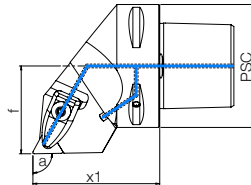

Wedge clamp
Direct coolant supply

Size	Code	Orientation	Insert	PSC	a	x1	f
C4	C4.DTGNR/L.27050.16DC	Right/Left	TNM..1604..	40	91°	50	27
C5	C5.DTGNR/L.35060.16DC	Right/Left	TNM..1604..	50	91°	60	35
C6	C6.DTGNR/L.45065.16DC	Right/Left	TNM..1604..	63	91°	65	45
C8	C8.DTGNR/L.55080.16DC	Right/Left	TNM..1604..	80	91°	80	55



Spare parts	Clamp	Clamp screw	Shim	Shim screw	Key	O-ring set	Nozzle
Code:	SPDR/L	VPA.0620.DC	PPPT.16	VPP.0512.KG	KLJ.I30	OR.VPA.DC	ML.M08 (C4) ML.M10 (C5-C8)

Turning tool holders - external

Wedge clamp
Direct coolant supply

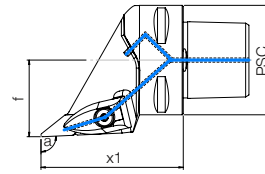

Size	Code	Orientation	Insert	PSC	a	x1	f
C4	C4.DVJNR/L.27062.16	Right/Left	VNM..1604..	40	93°	62	27
C5	C5.DVJNR/L.35065.16	Right/Left	VNM..1604..	50	93°	65	35
C6	C6.DVJNR/L.45065.16	Right/Left	VNM..1604..	63	93°	65	45
C8	C8.DVJNR/L.55080.16	Right/Left	VNM..1604..	80	93°	80	55

Spare parts	Clamp	Clamp screw	Shim	Shim screw	Key	Nozzle
Code:	SPDR/L	VPA.0620.DC	PPPV.16	VPP.0512.RG	KLJ.I30	ML.M08 (C4) ML.M10 (C5-C8)

Turning tool holders - external

Wedge clamp
Direct coolant supply

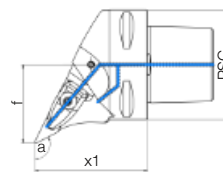

Size	Code	Orientation	Insert	PSC	a	x1	f
C4	C4.DVPCR/L.27062.16DC	Right/Left	VNM..1604..	40	118°	62	27
C5	C5.DVPCR/L.35060.16DC	Right/Left	VNM..1604..	50	118°	60	35
C6	C6.DVPCR/L.45065.16DC	Right/Left	VNM..1604..	63	118°	65	45
C8	C8.DVPCR/L.55080.16DC	Right/Left	VNM..1604..	80	118°	80	55

Spare parts	Clamp	Clamp screw	Shim	Shim screw	Key	Nozzle
Code:	SPDR/L	VPA.0620.DC	PPPV.16	VPP.0512.RG	KLJ.I30	ML.M08 (C4) ML.M10 (C5,C6)

Turning tool holders - external

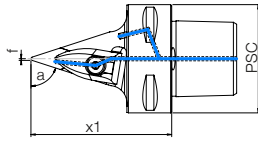

Wedge clamp
Direct coolant supply

Size	Code	Orientation	Insert	PSC	a	x1	f
C4	C4.DVNN.00062.16	Neutral	VNM..1604..	40	72.5°	62	0
C5	C5.DVNN.00065.16	Neutral	VNM..1604..	50	72.5°	65	0
C6	C6.DVNN.00065.16	Neutral	VNM..1604..	63	72.5°	65	0
C8	C8.DVNN.00080.16	Neutral	VNM..1604..	80	72.5°	80	0



Spare parts	Clamp	Clamp screw	Shim	Shim screw	Key	Nozzle
Code:	SPDR/L	VPA.0620.DC	PPP.V.16	VPP.0512.RG	KLJ.I30	ML.M08 (C4) ML.M10 (C5-C8)

Turning tool holders - external

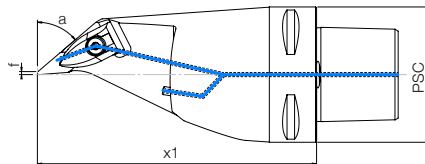

Wedge clamp
Direct coolant supply

Size	Code	Orientation	Insert	PSC	a	x1	f
C6	C6.DVMNL.00130.16	Left	VNM..1604..	63	50°	130	1.2
C8	C8.DVMNL.00160.16	Left	VNM..1604..	80	50°	160	1.2



Spare parts	Clamp	Clamp screw	Shim	Shim screw	Key	Nozzle
Code:	SPDR/L	VPA.0620.DC	PPP.V.16	VPP.0512.RG	KLJ.I30	ML.M10

Turning tool holders - external

Lever-lock clamp
Direct coolant supply

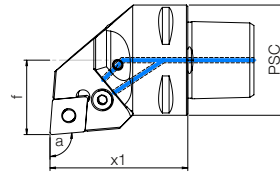

Size	Code	Orientation	Insert	PSC	a	x1	f
C4	C4.PCLNR/L.27050.12DC	Right/Left	CNM..1204..	40	95°	50	27
C5	C5.PCLNR/L.35060.12DC	Right/Left	CNM..1204..	50	95°	60	35
C6	C6.PCLNR/L.45065.12DC	Right/Left	CNM..1204..	63	95°	65	45
C6	C6.PCLNR/L.45165.12DC	Right/Left	CNM..1204..	63	95°	165	45
C8	C8.PCLNR/L.55080.12DC	Right/Left	CNM..1204..	80	95°	80	55

Spare parts	Lever	Lever screw	Shim	Shim pin	Key	Nozzle
Code:	POL.01	VPOL.0819	PPPC.12	OPP.01	KLJ.I30	ML.M4

Turning tool holders - external

Lever-lock clamp
Direct coolant supply

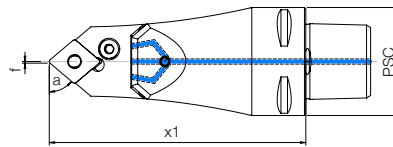

Size	Code	Orientation	Insert	PSC	a	x1	f
C4	C4.PCMNN.00095.12DC	Neutral	CNM..1204..	40	50°	95	0
C5	C5.PCMNN.00115.12DC	Neutral	CNM..1204..	50	50°	115	0
C6	C6.PCMNN.00115.12DC	Neutral	CNM..1204..	63	50°	115	0
C8	C8.PCMNN.00150.12DC	Neutral	CNM..1204..	80	50°	150	0

Spare parts	Lever	Lever screw	Shim	Shim pin	Key	Nozzle
Code:	POL.01	VPOL.0819	PPPC.12	OPP.01	KLJ.I30	ML.M4

Turning tool holders - external

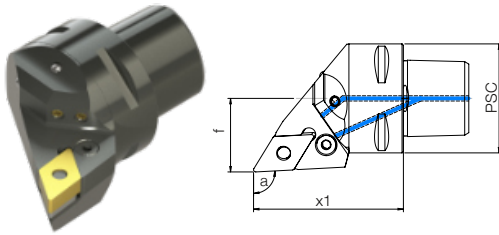

Lever-lock clamp
Direct coolant supply

Size	Code	Orientation	Insert	PSC	a	x1	f
C4	C4.PDJNR/L.27055.15DC	Right/Left	DNM..1506..	40	93°	55	27
C5	C5.PDJNR/L.35060.15DC	Right/Left	DNM..1506..	50	93°	60	35
C6	C6.PDJNR/L.45065.15DC	Right/Left	DNM..1506..	63	93°	65	45
C6	C6.PDJNR/L.45165.15DC	Right/Left	DNM..1506..	63	93°	165	45
C8	C8.PDJNR/L.55080.15DC	Right/Left	DNM..1506..	80	93°	80	55



Spare parts	Lever	Lever screw	Shim	Shim pin	Key	Nozzle
Code:	POL.02	VPOL.0819	PPPD.15	OPP.01	KLJ.I30	ML.M4

Turning tool holders - external

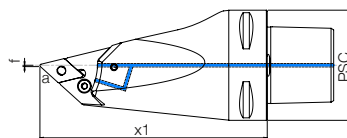

Lever-lock clamp
External coolant supply

Size	Code	Orientation	Insert	PSC	a	x1	f
C6	C6.PDMNR/L.00130.15DC	Right/Left	DNM..1506..	63	93°	130	0.6



Spare parts	Lever	Lever screw	Shim	Shim pin	Key	Nozzle
Code:	POL.02	VPOL.0819	PPPD.15	OPP.01	KLJ.I30	ML.M4



Turning tool holders - external

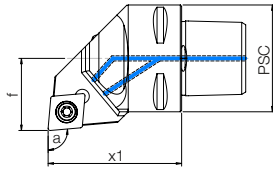

Screw clamp
Direct coolant supply

Size	Code	Orientation	Insert	PSC	a	x1	f
C4	C4.SCLCR/L.27050.12DC	Right/Left	CCM..1204..	40	95°	50	27
C5	C5.SCLCR/L.35060.12DC	Right/Left	CCM..1204..	50	95°	60	35
C6	C6.SCLCR/L.45065.12DC	Right/Left	CCM..1204..	63	95°	65	45



Spare parts	Insert screw	Shim	Shim screw	Key	Key	Nozzle
Code:	VPT.4516	PPVC.12	VPP.4513	KLJ.I45	KLJ.T20	ML.M4

Turning tool holders - external

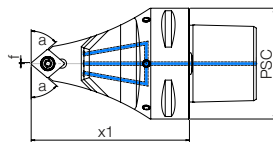

Screw clamp
Direct coolant supply

Size	Code	Orientation	Insert	PSC	a	x1	f
C6	C6.SCMCN.00090.12.DC	Neutral	CCM..1204..	63	50°	90	0



Spare parts	Insert screw	Shim	Shim screw	Key	Key	Nozzle
Code:	VPT.4516	PPVC.12	VPP.4513	KLJ.I45	KLJ.T20	ML.M4

Turning tool holders - external

Screw clamp
Direct coolant supply

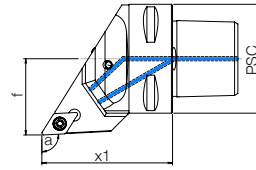

Size	Code	Orientation	Insert	PSC	a	x1	f
C4	C4.SDJCR/L.27050.11DC	Right/Left	DCM..11T3..	40	93°	50	27
C5	C5.SDJCR/L.35060.11DC	Right/Left	DCM..11T3..	50	93°	60	35
C6	C6.SDJCR/L.45065.11DC	Right/Left	DCM..11T3..	63	93°	65	45

Spare parts	Insert screw	Shim	Shim screw	Key	Key	Nozzle
Code:	VPT.3514	PPVD.11	VPP.3511	KLJ.I35	KLJ.T15	ML.M4

Turning tool holders - external

Screw clamp
Direct coolant supply

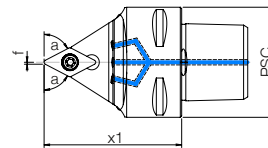

Size	Code	Orientation	Insert	PSC	a	x1	f
C4	C4.SDN CN.00050.11DC	Neutral	DCM..11T3..	40	62.5°	50	0
C5	C5.SDN CN.00060.11DC	Neutral	DCM..11T3..	50	62.5°	60	0

Spare parts	Insert screw	Shim	Shim screw	Key	Key	Nozzle
Code:	VPT.3514	PPVD.11	VPP.3511	KLJ.I35	KLJ.T15	ML.M4

Turning tool holders - external

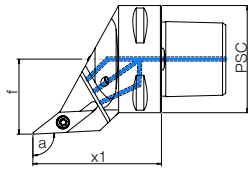

Screw clamp
Direct coolant supply

Size	Code	Orientation	Insert	PSC	a	x1	f
C4	C4.SVJBR/L.27050.11DC	Right/Left	VB(VC)..1102..	40	93°	50	27
C4	C4.SVJBR/L.27050.16DC	Right/Left	VB(VC)..1604..	40	93°	50	27
C5	C5.SVJBR/L.35060.11DC	Right/Left	VB(VC)..1102..	50	93°	60	35
C5	C5.SVJBR/L.35060.16DC	Right/Left	VB(VC)..1604..	50	93°	60	35
C6	C6.SVJBR/L.45065.11DC	Right/Left	VB(VC)..1102..	63	93°	65	45
C6	C6.SVJBR/L.45065.16DC	Right/Left	VB(VC)..1604..	63	93°	65	45



Spare parts	Insert screw	Shim	Shim screw	Key	Key	Nozzle
Code:	VPT.3508 (C4) VPT.3514 (C5,C6)	PPW.16	VPP.3508	KLJ.I35	KLJ.T15	ML.M4

Turning tool holders - external

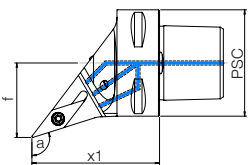

Screw clamp
External coolant supply

Size	Code	Orientation	Insert	PSC	a	x1	f
C4	C4.SVHBR/L.27050.16DC	Right/Left	VB(VC)..1604..	40	107.5°	50	27
C5	C5.SVHBR/L.35060.16DC	Right/Left	VB(VC)..1604..	50	107.5°	60	35
C6	C6.SVHBR/L.45065.16DC	Right/Left	VB(VC)..1604..	63	107.5°	65	45



Spare parts	Insert screw	Shim	Shim screw	Key	Key	Nozzle
Code:	VPT.3514	PPW.16	VPP.3511	KLJ.I35	KLJ.T15	ML.M4

Turning tool holders - external

Screw clamp
Direct coolant supply

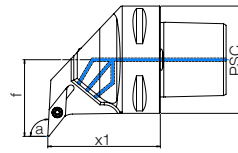

Size	Code	Orientation	Insert	PSC	a	x1	f
C6	C6.SVUBR/L.45065.16DC	Right/Left	VB(VC)..1604..	63	93°	63	45

Spare parts	Insert screw	Shim	Shim screw	Key	Key	Nozzle
Code:	VPT.3514	PPV.16	VPP.3511	KLJ.I35	KLJ.T15	ML.M4

Turning tool holders - external

Screw clamp
Direct coolant supply

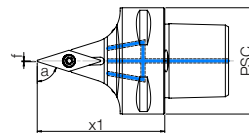

Size	Code	Orientation	Insert	PSC	a	x1	f
C4	C4.SWBN.00055.16DC	Neutral	VB(VC)..1604..	40	72.5°	55	0
C5	C5.SWBN.00060.16DC	Neutral	VB(VC)..1606..	50	72.5°	60	0
C6	C6.SWBN.00065.16DC	Neutral	VB(VC)..1608..	63	72.5°	65	0

Spare parts	Insert screw	Shim	Shim screw	Key	Key	Nozzle
Code:	VPT.3514	PPV.16	VPP.3511	KLJ.I35	KLJ.T15	ML.M4

Turning tool holders - external

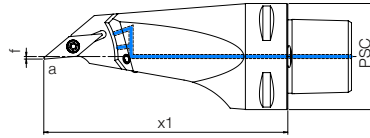

Screw clamp
Direct coolant supply

Size	Code	Orientation	Insert	PSC	a	x1	f
C5	C5.SVMBL.00115.16DC	Left	VB(VC)..1604..	50	95°	115	1,2
C6	C6.SVMBL.00130.16DC	Left	VB(VC)..1604..	63	95°	130	1,2
C6	C6.SVMBL.33120.16DC	Left	VB(VC)..1604..	63	95°	120	33



Spare parts	Insert screw	Shim	Shim screw	Key	Key	Nozzle
Code:	VPT.3514	PPV.16	VPP.3511	KLJ.I35	KLJ.T15	ML.M4



Turning tool holders - internal

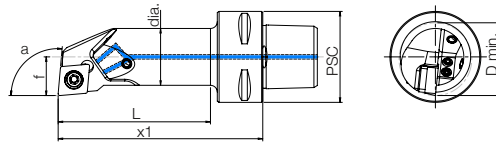

Screw clamp
Direct coolant supply

Size	Code	Orientation	Insert	PSC	a	x1	f	dia.	D min.	L
C4	C4.SCLCR/L.17090.12DC	Right/Left	CCM..1204..	40	95°	50	17	25	32	69
C5	C5.SCLCR/L.17090.12DC	Right/Left	CCM..1204..	50	95°	90	17	25	32	67



Spare parts	Insert screw	Shim	Shim screw	Key	Key	Nozzle
Code:	VPT.4512	PPVC.12	VPP.4508	KLJ.I45	KLJ.T20	ML.M4

Turning tool holders - internal

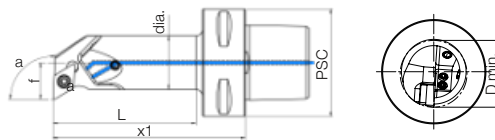

Screw clamp
Direct coolant supply

Size	Code	Orientation	Insert	PSC	a	x1	f	dia.	D min.	L
C4	C4.SDUCR/L.13080.11DC	Right/Left	DCM..11T3..	40	93°	80	13	20	25	58
C4	C4.SDUCR/L.17090.11DC	Right/Left	DCM..11T3..	40	93°	90	17	20	25	58
C5	C5.SDUCR/L.13080.11DC	Right/Left	DCM..11T3..	50	93°	80	13	25	32	69
C5	C5.SDUCR/L.17090.11DC	Right/Left	DCM..11T3..	50	93°	90	17	25	32	69



Spare parts	Insert screw	Shim	Shim screw	Key	Key	Nozzle
Code:	VPT.3511	PPVD.11	VPP.3508	KLJ.I35	KLJ.T15	ML.M4

Turning tool holders - external thread

Screw clamp
Direct coolant supply

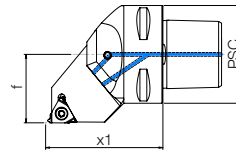

Size	Code	Orientation	Insert	PSC	x1	f
C4	C4.SER/L.27050.16DC	Right/Left	16ER/L	40	50	27
C5	C5.SER/L.35060.16DC	Right/Left	16ER/L	50	60	35
C6	C6.SER/L.45065.16DC	Right/Left	16ER/L	63	65	45

Spare parts	Insert screw	Shim	Shim screw	Key	Key	Nozzle
Code:	VPT.3514	PPVN.16	VPP.3511	KLJ.I35	KLJ.T15	ML.M4

Turning tool holders - internal thread

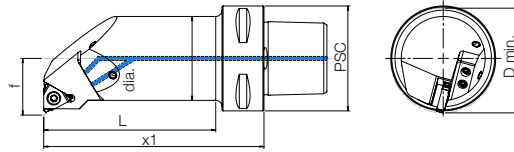

Screw clamp
Direct coolant supply

Size	Code	Orientation	Insert	PSC	x1	L	f	dia.	D.min
C4	C4.SIR/L.14060.16DC	Right/Left	16IR/L	40	60	38	14	20	33
C4	C4.SIR/L.17070.16DC	Right/Left	16IR/L	40	70	48	17	25	33
C4	C4.SIR/L.22090.16DC	Right/Left	16IR/L	40	90	69	22	32	40
C5	C5.SIR/L.17070.16DC	Right/Left	16IR/L	50	70	47	17	25	33
C5	C5.SIR/L.22090.16DC	Right/Left	16IR/L	50	90	68	22	32	33
C5	C5.SIR/L.27105.16DC	Right/Left	16IR/L	50	105	84	27	40	40
C6	C6.SIR/L.17075.16DC	Right/Left	16IR/L	63	75	48	17	25	33
C6	C6.SIR/L.22090.16DC	Right/Left	16IR/L	63	90	64	22	32	33
C6	C6.SIR/L.27105.16DC	Right/Left	16IR/L	63	105	80	17	40	40



Spare parts	Insert screw	Shim	Shim screw	Key	Key	Nozzle
Code:	VPT.3514	PPVN.16	VPP.3511	KLJ.I35	KLJ.T15	ML.M4

Rectangular shank adaptors

Internal coolant supply

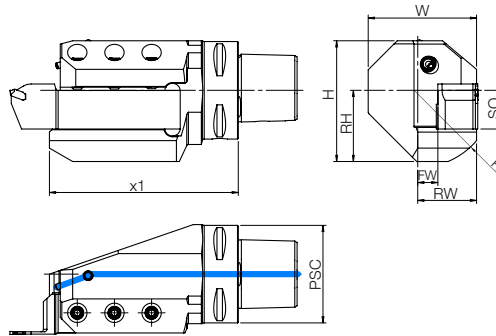

Radial

Size	Code	Orientation	PSC	X1	SQ	H	W	RH	RW	FW	R	bar	kg
C4	C4.QSHR/L.23104.16DC	Right/Left	40	104	16	50.5	43.5	30	23	7	32	150	1
C5	C5.QSHR/L.095.20DC	Right/Left	50	95	20	69	55.5	37	30	27	42.5	150	1.6
C6	C6.QSHR/L.105.20DC	Right/Left	63	105	20	69	63.5	37	30	35	42.5	150	2.3
C6	C6.QSHR/L.122.25DC	Right/Left	63	122	25	78	70.0	46	38	45	50	150	2.9
C8	C8.QSHR/L.122.25DC	Right/Left	80	122	25	86	80.0	46	40	45	51.5	150	4.3

Rectangular shank adaptors

Internal coolant supply

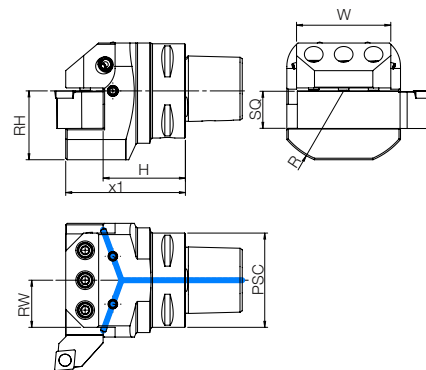

Axial

Size	Code	Orientation	PSC	X1	SQ	H	W	RW	RH	R	bar	kg
C4	C4.QSHA.25046.16DC	Right/Left	40	46	16	30	40	20	32	37	150	0.6
C5	C5.QSHA.065.20DC	Right/Left	50	65	20	45	64	32	37	42.5	150	1.4
C6	C6.QSHA.080.25DC	Right/Left	63	80	25	50	64	32	46	50	150	1.8
C8	C8.QSHA.075.25DC	Right/Left	80	75	25	50	80	38	46	51.5	150	3.0

Rectangular shank adaptors

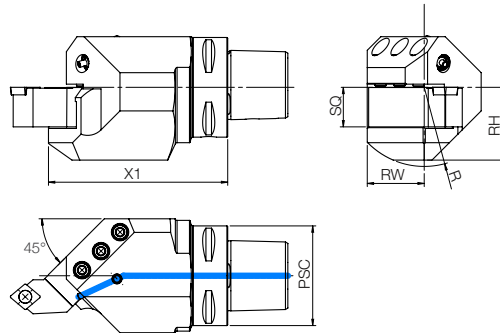

Internal coolant supply

Size	Code	Orientation	PSC	X1	SQ	RH	RW	R	bar	kg
C5	C5.QSHR/L45.085.20DC	Right/Left	50	85	20	37	32	42.5	150	1.6
C6	C6.QSHR/L45.114.25DC	Right/Left	63	114	25	46	36	50	150	2.2
C8	C8.QSHR/L45.135.32DC	Right/Left	80	135	32	46	40	55	150	6.8

45°

Blank bars

Cone and flange hardened and finished.
 Machineable soft body.
 Pre-balanced

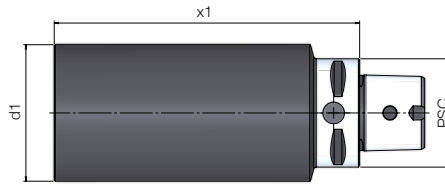

	Size	Code	PSC	d1	x1
PSC	C4	C4.RL40.100	40	40	100
	C4	C4.RL40.200	40	40	200
	C4	C4.RL63.200	40	63	200
	C4	C4.RL80.100	40	80	100
	C5	C5.RL50.100	50	50	100
	C5	C5.RL50.200	50	50	200
	C5	C5.RL63.200	50	63	200
	C5	C5.RL80.100	50	80	100
	C6	C6.RL63.160	63	63	160
	C6	C6.RL63.250	63	63	250
	C6	C6.RL80.200	63	80	200
	C6	C6.RL100.160	63	100	160
	C8	C8.RL80.160	80	80	160
	C8	C8.RL80.250	80	80	250
	C8	C8.RL100.160	80	100	160
	C8	C8.RL100.250	80	100	250

Boring bar and indexable drills holders

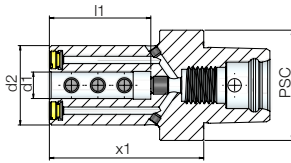

Direct coolant supply
Internal coolant supply

Size	Code	d1	PSC	x1	d2	l1
C4	C4.BBX06.060DC	6	40	60	30	42
C4	C4.BBX08.060DC	8	40	60	32	42
C4	C4.BBX10.060DC	10	40	60	34	42
C4	C4.BBX12.065DC	12	40	65	36	46
C4	C4.BBX16.070DC	16	40	70	40	49
C5	C5.BBX06.065DC	6	50	65	30	42
C5	C5.BBX08.065DC	8	50	65	32	42
C5	C5.BBX10.065DC	10	50	65	34	42
C5	C5.BBX12.070DC	12	50	70	36	46
C5	C5.BBX16.070DC	16	50	70	40	49
C5	C5.BBX20.075DC	20	50	75	45	54
C5	C5.BBX25.080DC	25	50	80	54	57
C6	C6.BBX06.065DC	6	63	65	30	35
C6	C6.BBX08.065DC	8	63	65	32	37
C6	C6.BBX10.070DC	10	63	70	34	42
C6	C6.BBX12.070DC	12	63	70	36	46
C6	C6.BBX16.075DC	16	63	75	40	49
C6	C6.BBX20.080DC	20	63	80	50	51
C6	C6.BBX25.085DC	25	63	85	50	51
C6	C6.BBX32.085DC	32	63	85	50	51
C6	C6.BBX40.095DC	40	63	95	50	51
C8	C8.BBX08.070DC	8	80	70	32	37
C8	C8.BBX10.070DC	10	80	70	34	42
C8	C8.BBX12.070DC	12	80	70	36	46
C8	C8.BBX16.070DC	16	80	70	40	49
C8	C8.BBX20.075DC	20	80	75	50	51
C8	C8.BBX25.085DC	25	80	85	50	57

PSC

PSC Reduction holders

Internal coolant supply

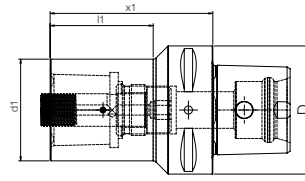

	PSC	Toolside PSC	Code	D	d1	x1	l1
PSC	C4	C3	C4.REC3.055	40	32	55	31
	C5	C3	C5.REC3.060	50	32	60	40
	C5	C4	C5.REC4.065	50	40	65	40
	C5	C4	C5.REC4.085	50	40	85	12
	C6	C3	C6.REC3.070	63	32	70	39
	C6	C4	C6.REC4.080	63	40	80	51
	C6	C5	C6.REC5.080	63	50	80	51
	C6	C5	C6.REC5.110	63	50	110	12
	C8	C3	C8.REC3.060	80	32	60	30
	C8	C4	C8.REC4.070	80	40	70	40
	C8	C5	C8.REC5.080	80	50	80	50
	C8	C5	C8.REC5.120	80	50	120	90
	C8	C6	C8.REC6.080	80	63	80	50

Quick-change PSC reduction holder

Internal coolant supply

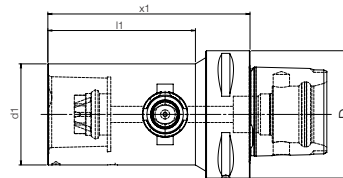

	PSC	Toolside PSC	Code	D	d1	x1	l1	Max rpm
PSC	C5	C4	C5.REC4.085.QC	50	40	85	60.5	28 000
	C6	C5	C6.REC6.100.QC	63	50	100	73	20 000
	C8	C6	C8.REC6.120.QC	80	63	120	84.5	14 000

PSC Extension holders

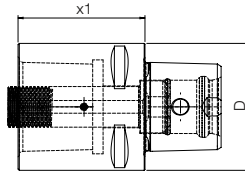

Internal coolant supply

PSC	Code	D	l1
C3	C3.EX.060	32	60
C3	C3.EX.080	32	80
C4	C4.EX.040	40	40
C4	C4.EX.060	40	60
C4	C4.EX.080	40	80
C5	C5.EX.050	50	50
C5	C5.EX.080	50	80
C5	C5.EX.100	50	100
C6	C6.EX.060	63	60
C6	C6.EX.100	63	100
C6	C6.EX.140	63	140
C8	C8.EX.065	80	65
C8	C8.EX.100	80	100
C8	C8.EX.125	80	125

PSC

Quick-change PSC Extension holders

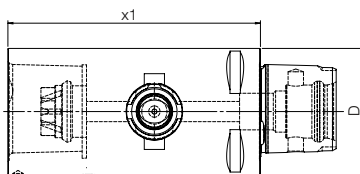

Internal coolant supply

PSC	Code	d1	l1	Max rpm
C4	C4.EX.085.QC	40	85	39 000
C5	C5.EX.100.QC	50	100	28 000
C6	C6.EX.115.QC	63	115	20 000
C8	C8.EX.145.QC	80	145	14 000

PSC

ER Collet chucks

Internal coolant supply
 Radial runout $\leq 0,003$ mm
 G2.5 at 25 000 min⁻¹

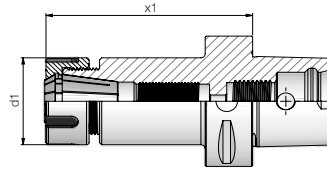

	Size	Code	ER	Range	PSC	x1	d2
PSC	C3	C3.ER16.045	ER16		32	45	
	C3	C3.ER20.045	ER20		32	45	
	C4	C4.ER16.070	ER16	1 - 10	40	70	28
	C4	C4.ER20.052	ER20	1 - 13	40	52	35
	C4	C4.ER25.052	ER25	1 - 16	40	52	42
	C4	C4.ER32.054	ER32	2 - 20	40	54	50
	C5	C5.ER16.055	ER16	1 - 10	50	55	28
	C5	C5.ER16.100	ER16	1 - 10	50	100	28
	C5	C5.ER16.130	ER16	1 - 10	50	130	28
	C5	C5.ER20.055	ER20	1 - 13	50	55	35
	C5	C5.ER20.100	ER20	1 - 13	50	100	35
	C5	C5.ER20.130	ER20	1 - 13	50	130	35
	C5	C5.ER25.055	ER25	1 - 16	50	55	42
	C5	C5.ER25.100	ER25	1 - 16	50	100	42
	C5	C5.ER25.130	ER25	1 - 16	50	130	42
	C5	C5.ER32.057	ER32	2 - 20	50	57	50
	C5	C5.ER32.100	ER32	2 - 20	50	100	50
	C5	C5.ER32.130	ER32	2 - 20	50	130	50
	C5	C5.ER40.060	ER40	3 - 26	50	60	63
	C6	C6.ER16.060	ER16	1 - 10	63	60	28
	C6	C6.ER16.100	ER16	1 - 10	63	100	28
	C6	C6.ER16.130	ER16	1 - 10	63	130	28
	C6	C6.ER20.060	ER20	1 - 13	63	60	35
	C6	C6.ER20.100	ER20	1 - 13	63	100	35
	C6	C6.ER20.130	ER20	1 - 13	63	130	35
	C6	C6.ER25.060	ER25	1 - 16	63	60	42
	C6	C6.ER25.100	ER25	1 - 16	63	100	42
	C6	C6.ER25.130	ER25	1 - 16	63	130	42
	C6	C6.ER25.160	ER25	1 - 16	63	160	42
	C6	C6.ER32.060	ER32	2 - 20	63	60	50
	C6	C6.ER32.100	ER32	2 - 20	63	100	50
	C6	C6.ER32.130	ER32	2 - 20	63	130	52
	C6	C6.ER32.160	ER32	2 - 20	63	160	52
	C6	C6.ER40.065	ER40	3 - 26	63	65	63
	C6	C6.ER40.130	ER40	3 - 26	63	130	63

ER Collet chucks

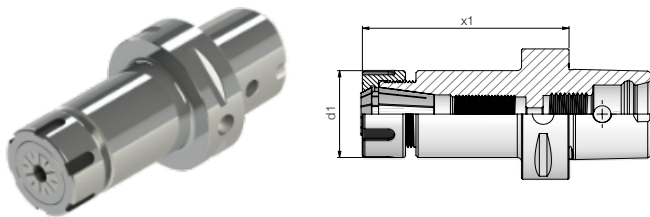

Internal coolant supply
 Radial runout $\leq 0,003$ mm
 G2.5 at 25 000 min⁻¹

Size	Code	ER	Range	PSC	x1	d2
C8	C8.ER16.100	ER16	1 - 10	80	100	28
C8	C8.ER20.065	ER20	1 - 13	80	65	35
C8	C8.ER20.100	ER20	1 - 13	80	100	35
C8	C8.ER25.070	ER25	1 - 16	80	70	42
C8	C8.ER25.100	ER25	1 - 16	80	100	42
C8	C8.ER25.130	ER25	1 - 16	80	130	42
C8	C8.ER25.160	ER25	1 - 16	80	160	42
C8	C8.ER32.070	ER32	1 - 16	80	70	50
C8	C8.ER32.100	ER32	2 - 20	80	100	50
C8	C8.ER32.130	ER32	2 - 20	80	130	50
C8	C8.ER32.160	ER32	2 - 20	80	160	50
C8	C8.ER40.070	ER40	3 - 26	80	70	63

PSC

ER Collet chucks - short adaptor

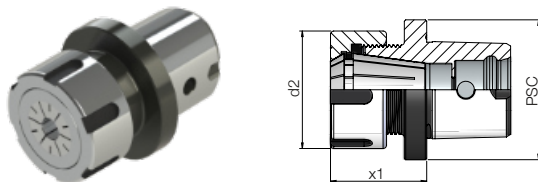

Internal coolant supply

Size	Code	ER	Range	PSC	x1	d2
C3	C3.ER16.030	ER16	1 - 10	32	30	28
C3	C3.ER20.035	ER20	1 - 13	32	35	35
C3	C3.ER25.044	ER25	1 - 16	32	44	42
C4	C4.ER20.032	ER20	1 - 13	40	32	35
C4	C4.ER25.035	ER25	1 - 16	40	35	42
C4	C4.ER32.052	ER32	2 - 20	40	52	50
C5	C5.ER25.034	ER25	1 - 16	50	34	42
C5	C5.ER32.041	ER32	2 - 20	50	41	50
C5	C5.ER40.058	ER40	3 - 26	50	58	63
C6	C6.ER32.042	ER32	2 - 20	63	42	50
C6	C6.ER40.048	ER40	3 - 26	63	48	63

PSC

End mill holders

Internal coolant supply
 Radial runout $\leq 0,003$ mm
 G2.5 at 25 000 min⁻¹

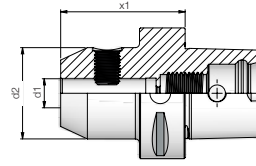

	Size	Code	d1	PSC	x1	d2
PSC	C4	C4.WE06.050	6	40	50	25
	C4	C4.WE08.050	8	40	50	28
	C4	C4.WE10.050	10	40	50	35
	C4	C4.WE12.055	12	40	55	42
	C4	C4.WE14.055	14	40	55	44
	C4	C4.WE16.055	16	40	55	48
	C5	C5.WE06.050	6	50	50	25
	C5	C5.WE08.050	8	50	50	28
	C5	C5.WE10.050	10	50	50	35
	C5	C5.WE12.060	12	50	60	42
	C5	C5.WE14.060	14	50	60	44
	C5	C5.WE16.060	16	50	60	48
	C5	C5.WE18.060	18	50	60	50
	C5	C5.WE20.060	20	50	60	52
	C5	C5.WE25.080	25	50	80	65
	C6	C6.WE06.055	6	63	55	25
	C6	C6.WE08.055	8	63	55	28
	C6	C6.WE10.060	10	63	60	35
	C6	C6.WE12.060	12	63	60	42
	C6	C6.WE14.060	14	63	60	44
	C6	C6.WE16.065	16	63	65	48
	C6	C6.WE18.065	18	63	65	50
	C6	C6.WE20.065	20	63	65	52
	C6	C6.WE25.080	25	63	80	65
	C6	C6.WE32.090	32	63	90	72
	C6	C6.WE40.100	40	63	100	90
	C8	C8.WE06.070	6	80	70	25
	C8	C8.WE08.070	8	80	70	28
	C8	C8.WE10.070	10	80	70	35
	C8	C8.WE12.070	12	80	70	42
	C8	C8.WE14.070	14	80	70	44
	C8	C8.WE16.070	16	80	70	48
	C8	C8.WE18.070	18	80	70	50
	C8	C8.WE20.070	20	80	70	52
	C8	C8.WE25.080	25	80	80	65
	C8	C8.WE32.080	32	80	80	72
	C8	C8.WE40.110	40	80	110	90

End mill holders - short adaptor

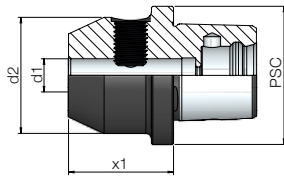

Internal coolant supply

Size	Code	d1	PSC	x1	d2
C3	C3.WE06.033	6	32	33	19
C3	C3.WE08.033	8	32	33	21
C3	C3.WE10.037	10	32	37	28
C3	C3.WE12.042	12	32	43	34
C3	C3.WE14.043	14	32	43	36
C3	C3.WE16.051	16	32	51	38
C4	C4.WE06.030	6	40	30	19
C4	C4.WE08.030	8	40	30	21
C4	C4.WE10.034	10	40	34	28
C4	C4.WE12.039	12	40	39	34
C4	C4.WE14.039	14	40	39	36
C4	C4.WE16.043	16	40	43	38
C4	C4.WE18.043	18	40	43	40
C4	C4.WE20.045	20	40	45	45
C5	C5.WE06.029	6	50	29	19
C5	C5.WE08.029	8	50	29	21
C5	C5.WE10.033	10	50	33	28
C5	C5.WE12.038	12	50	38	34
C5	C5.WE14.038	14	50	38	36
C5	C5.WE16.041	16	50	41	38
C5	C5.WE18.042	18	50	42	40
C5	C5.WE20.044	20	50	44	45
C5	C5.WE25.050	25	50	50	51
C6	C6.WE06.030	6	63	30	19
C6	C6.WE08.031	8	63	31	21
C6	C6.WE10.034	10	63	34	28
C6	C6.WE12.037	12	63	37	34
C6	C6.WE14.037	14	63	37	36
C6	C6.WE16.041	16	63	41	38
C6	C6.WE18.041	18	63	41	40
C6	C6.WE20.043	20	63	43	45
C6	C6.WE25.050	25	63	50	51
C6	C6.WE32.054	32	63	54	72

PSC

“3 in 1” THERMO Shrink-fit chucks

Internal and/or direct coolant supply
 Radial runout ≤ 0,003 mm
 G2.5 at 25 000 min⁻¹

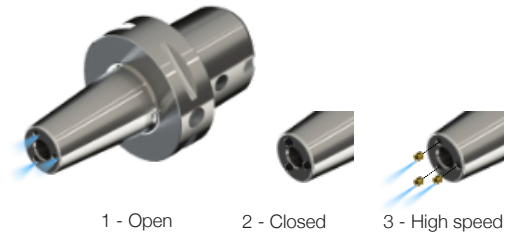
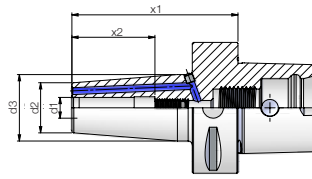

	Size	Code	d1	PSC	x1	d2	d3	x2
PSC	C4	C4.SF03.075	3	40	75	9	16	-
	C4	C4.SF03.120	3	40	120	9	18	-
	C4	C4.SF04.075	4	40	75	10	17	-
	C4	C4.SF04.120	4	40	120	10	19	-
	C4	C4.SF05.075	5	40	75	11	18	-
	C4	C4.SF05.120	5	40	120	11	20	-
	C4	C4.SF06.075.IK	6	40	75	20	27	36
	C4	C4.SF06.120.IK	6	40	120	20	27	36
	C4	C4.SF08.075.IK	8	40	75	20	27	36
	C4	C4.SF08.120.IK	8	40	120	20	27	36
	C4	C4.SF10.075.IK	10	40	75	24	32	42
	C4	C4.SF10.120.IK	10	40	120	24	32	42
	C4	C4.SF12.075.IK	12	40	75	24	32	47
	C4	C4.SF12.120.IK	12	40	120	24	32	47
	C4	C4.SF14.080.IK	14	40	80	27	34	47
	C4	C4.SF14.120.IK	14	40	120	27	34	47
	C4	C4.SF16.080.IK	16	40	80	27	34	50
	C4	C4.SF16.120.IK	16	40	120	27	34	50
	C5	C5.SF03.075	3	50	75	9	16	-
	C5	C5.SF03.120	3	50	120	9	18	-
	C5	C5.SF04.075	4	50	75	10	17	-
	C5	C5.SF04.120	4	50	120	10	19	-
	C5	C5.SF05.075	5	50	75	11	18	-
	C5	C5.SF05.120	5	50	120	11	20	-
	C5	C5.SF06.075.IK	6	50	75	20	27	36
	C5	C5.SF06.120.IK	6	50	120	20	27	36
	C5	C5.SF08.075.IK	8	50	75	20	27	36
	C5	C5.SF08.120.IK	8	50	120	20	27	36
	C5	C5.SF10.075.IK	10	50	75	24	32	42
	C5	C5.SF10.120.IK	10	50	120	24	32	42
	C5	C5.SF12.075.IK	12	50	75	24	32	47
	C5	C5.SF12.120.IK	12	50	120	24	32	47
C5	C5.SF14.080.IK	14	50	80	27	34	47	
C5	C5.SF14.120.IK	14	50	120	27	34	47	
C5	C5.SF16.080.IK	16	50	80	27	34	50	
C5	C5.SF16.120.IK	16	50	120	27	34	50	
C5	C5.SF18.080.IK	18	50	80	33	42	50	
C5	C5.SF18.120.IK	18	50	120	33	42	50	
C5	C5.SF20.085.IK	20	50	85	33	42	52	
C5	C5.SF20.120.IK	20	50	120	33	42	52	

“3 in 1” THERMO Shrink-fit chucks

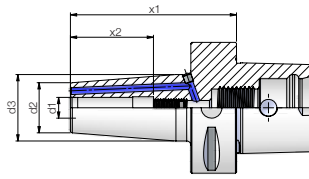
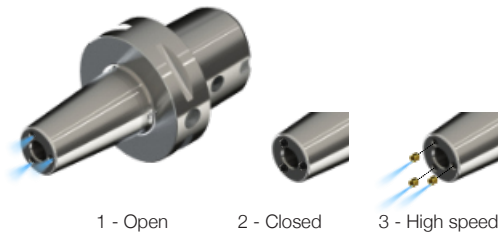

Internal and/or direct coolant supply

Radial runout $\leq 0,003$ mm

G2.5 at 25 000 min⁻¹

Size	Code	d1	PSC	x1	d2	d3	x2
C6	C6.SF03.080	3	63	80	9	16	-
C6	C6.SF03.120	3	63	120	9	18	-
C6	C6.SF04.080	4	63	80	10	17	-
C6	C6.SF04.120	4	63	120	10	19	-
C6	C6.SF05.080	5	63	80	11	18	-
C6	C6.SF05.120	5	63	120	11	20	-
C6	C6.SF06.080.IK	6	63	80	20	27	36
C6	C6.SF06.120.IK	6	63	120	20	27	36
C6	C6.SF06.160.IK	6	63	160	20	27	36
C6	C6.SF08.080.IK	8	63	80	20	27	36
C6	C6.SF08.120.IK	8	63	120	20	27	36
C6	C6.SF08.160.IK	8	63	160	20	27	36
C6	C6.SF10.080.IK	10	63	80	24	32	40
C6	C6.SF10.120.IK	10	63	120	24	32	40
C6	C6.SF10.160.IK	10	63	160	24	32	40
C6	C6.SF12.080.IK	12	63	80	24	32	47
C6	C6.SF12.120.IK	12	63	120	24	32	47
C6	C6.SF12.160.IK	12	63	160	24	32	47
C6	C6.SF14.085.IK	14	63	85	27	34	47
C6	C6.SF14.120.IK	14	63	120	27	34	47
C6	C6.SF16.085.IK	16	63	85	27	34	50
C6	C6.SF16.120.IK	16	63	120	27	34	50
C6	C6.SF16.160.IK	16	63	160	27	34	50
C6	C6.SF18.085.IK	18	63	85	33	42	50
C6	C6.SF18.120.IK	18	63	120	33	42	50
C6	C6.SF20.085.IK	20	63	85	33	42	50
C6	C6.SF20.120.IK	20	63	120	33	42	50
C6	C6.SF20.160.IK	20	63	160	33	42	50
C6	C6.SF25.090.IK	25	63	90	44	53	58
C6	C6.SF25.120.IK	25	63	120	44	53	58
C6	C6.SF32.095.IK	32	63	95	44	53	63
C6	C6.SF32.120.IK	32	63	120	44	53	63

PSC

“3 in 1” THERMO Shrink-fit chucks

Internal and/or direct coolant supply
 Radial runout $\leq 0,003$ mm
 G2.5 at 25 000 min⁻¹

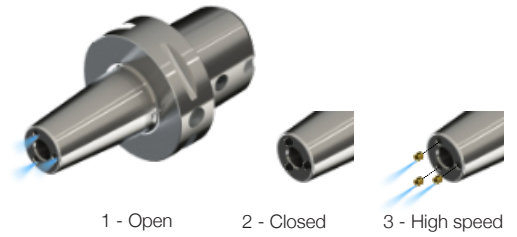
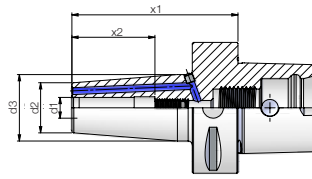

	Size	Code	d1	PSC	x1	d2	d3	x2
PSC	C8	C8.SF03.085	3	80	85	9	16	-
	C8	C8.SF03.130	3	80	130	9	18	-
	C8	C8.SF04.085	4	80	85	10	17	-
	C8	C8.SF04.130	4	80	130	10	19	-
	C8	C8.SF05.085	5	80	85	11	18	-
	C8	C8.SF05.130	5	80	130	11	20	-
	C8	C8.SF06.085.IK	6	80	85	20	27	36
	C8	C8.SF06.130.IK	6	80	130	20	27	36
	C8	C8.SF08.085.IK	8	80	85	20	27	36
	C8	C8.SF08.130.IK	8	80	130	20	27	36
	C8	C8.SF10.085.IK	10	80	85	24	32	42
	C8	C8.SF10.130.IK	10	80	130	24	32	42
	C8	C8.SF12.085.IK	12	80	85	24	32	47
	C8	C8.SF12.130.IK	12	80	130	24	32	47
	C8	C8.SF14.085.IK	14	80	85	27	34	47
	C8	C8.SF14.130.IK	14	80	130	27	34	47
	C8	C8.SF16.090.IK	16	80	90	27	34	50
	C8	C8.SF16.130.IK	16	80	130	27	34	50
	C8	C8.SF18.090.IK	18	80	90	33	42	50
	C8	C8.SF18.130.IK	18	80	130	33	42	50
C8	C8.SF20.090.IK	20	80	90	33	42	52	
C8	C8.SF20.130.IK	20	80	130	33	42	52	
C8	C8.SF25.090.IK	25	80	90	44	53	58	
C8	C8.SF25.130.IK	25	80	130	44	53	58	
C8	C8.SF32.090.IK	32	80	90	44	53	63	
C8	C8.SF32.130.IK	32	80	130	44	53	63	

“3 in 1” THERMO Shrink-fit chucks - short adaptors

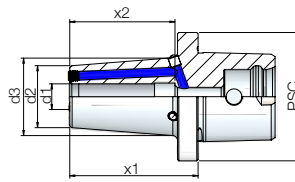
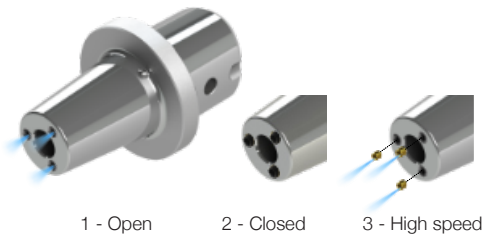

Internal and/or direct coolant supply

Size	Code	d1	PSC	x1	d2	d3	x2
C3	C3.SF03.048	3	32	48	9	16	-
C3	C3.SF04.048	4	32	48	10	17	-
C3	C3.SF05.048	5	32	48	11	18	-
C3	C3.SF06.048.IK	6	32	48	20	24.5	36
C3	C3.SF08.048.IK	8	32	48	20	24.5	36
C3	C3.SF10.048.IK	10	32	48	22.5	27	41
C3	C3.SF12.048.IK	12	32	48	22.5	27	46
C4	C4.SF03.049	3	40	49	9	16	-
C4	C4.SF04.049	4	40	49	10	17	-
C4	C4.SF05.049	5	40	49	11	18	-
C4	C4.SF06.049.IK	6	40	49	20	24.5	36
C4	C4.SF08.049.IK	8	40	49	20	24.5	36
C4	C4.SF10.049.IK	10	40	49	24	28.5	41
C4	C4.SF12.049.IK	12	40	49	24	28.5	46
C4	C4.SF14.049.IK	14	40	49	27	31.5	46
C4	C4.SF16.054.IK	16	40	54	27	32.3	49
C5	C5.SF03.050	3	50	50	9	16	-
C5	C5.SF04.050	4	50	50	10	17	-
C5	C5.SF05.050	5	50	50	11	18	-
C5	C5.SF06.050.IK	6	50	50	20	24.5	36
C5	C5.SF08.050.IK	8	50	50	20	24.5	36
C5	C5.SF10.050.IK	10	50	50	24	28.5	41
C5	C5.SF12.050.IK	12	50	50	24	28.5	46
C5	C5.SF14.050.IK	14	50	50	27	31.5	46
C5	C5.SF16.055.IK	16	50	55	27	32.3	49
C6	C6.SF03.052	3	63	52	9	16	-
C6	C6.SF04.052	4	63	52	10	17	-
C6	C6.SF05.052	5	63	52	11	18	-
C6	C6.SF06.052.IK	6	63	52	20	24.5	36
C6	C6.SF08.052.IK	8	63	52	20	24.5	36
C6	C6.SF10.052.IK	10	63	52	24	28.5	41
C6	C6.SF12.052.IK	12	63	52	24	28.5	46
C6	C6.SF14.052.IK	14	63	52	27	31.5	46
C6	C6.SF16.057.IK	16	63	57	27	32.3	49

PSC

Shell mill holders

Internal coolant supply
 Radial runout $\leq 0,003$ mm
 G2.5 at 25 000 min⁻¹

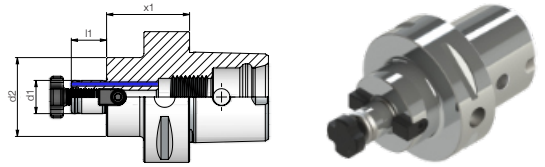

	Size	Code	d1	PSC	x1	d2	l1
PSC	C4	C4.AD16.035.IK	16	40	35	28	17
	C4	C4.AD22.025.IK	22	40	25	48	19
	C5	C5.AD16.035.IK	16	50	35	38	17
	C5	C5.AD22.025.IK	22	50	25	48	19
	C5	C5.AD27.025.IK	27	50	25	56	21
	C5	C5.AD32.040.IK	32	50	40	63	24
	C6	C6.AD16.040.IK	16	63	40	38	17
	C6	C6.AD22.025.IK	22	63	25	48	19
	C6	C6.AD27.025.IK	27	63	25	56	21
	C6	C6.AD32.025.IK	32	63	25	63	24
	C6	C6.AD40.050.IK	40	63	50	87	27
	C8	C8.AD16.050.IK	16	80	50	38	17
	C8	C8.AD22.030.IK	22	80	30	48	19
	C8	C8.AD27.030.IK	27	80	30	56	21
	C8	C8.AD32.030.IK	32	80	30	63	24
	C8	C8.AD40.060.IK	40	80	60	87	27

Shell mill holders - short adaptors

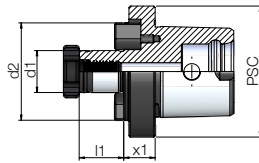

Internal coolant supply

Size	Code	d1	PSC	x1	d2	l1
C3	C3.AD16.015	16	32	15	36	17
C3	C3.AD22.019	22	32	19	45	19
C4	C4.AD16.010	16	40	10	40	17
C4	C4.AD22.012	22	40	12	45	19
C5	C5.AD16.010	16	50	10	50	17
C5	C5.AD22.012	22	50	12	50	19
C5	C5.AD27.012	27	50	12	50	21
C5	C5.AD32.018	32	50	18	63	24
C6	C6.AD16.010	16	63	10	63	17
C6	C6.AD22.010	22	63	10	63	19
C6	C6.AD27.011	27	63	11	63	21
C6	C6.AD32.012	32	63	12	63	24

PSC

PSC quick-change tool holders

Complete your transition to PSC tool holding with our PSC quick-change tool holders and take your machine's productivity to the next level.

- Single, double, Y, X, or double Y static holders
- Static holders for both OD or ID operation
- Driven tool holders - axial and radial
- Cylindrical shank tool holders and cut off holders
- Compatible with turrets of major machine tool builders

**More information at
www.sab.hr**







SAB



Find additional information and
product catalogues

www.sab.hr

SAB d.o.o.
Podborska 1b / 43500 Daruvar
tel. + 385 43 675 850
fax. + 385 43 334 700
sab@sab.hr / www.sab.hr

Note: Product photos and illustrations are not binding. Product descriptions, technical specifications and dimensions are binding only when explicitly agreed upon. We reserve right to make technical modifications as well as price changes. We take no liability for print or type errors. Only our terms and conditions are valid. 02/2024